



Series
EPX

CRIMP POWER PIN CONTACT
FOR SIZE 5 CAVITY.
FOR AWG 8 and 10 CABLE.

Issue:
May 07, 99

Page
1 / 1

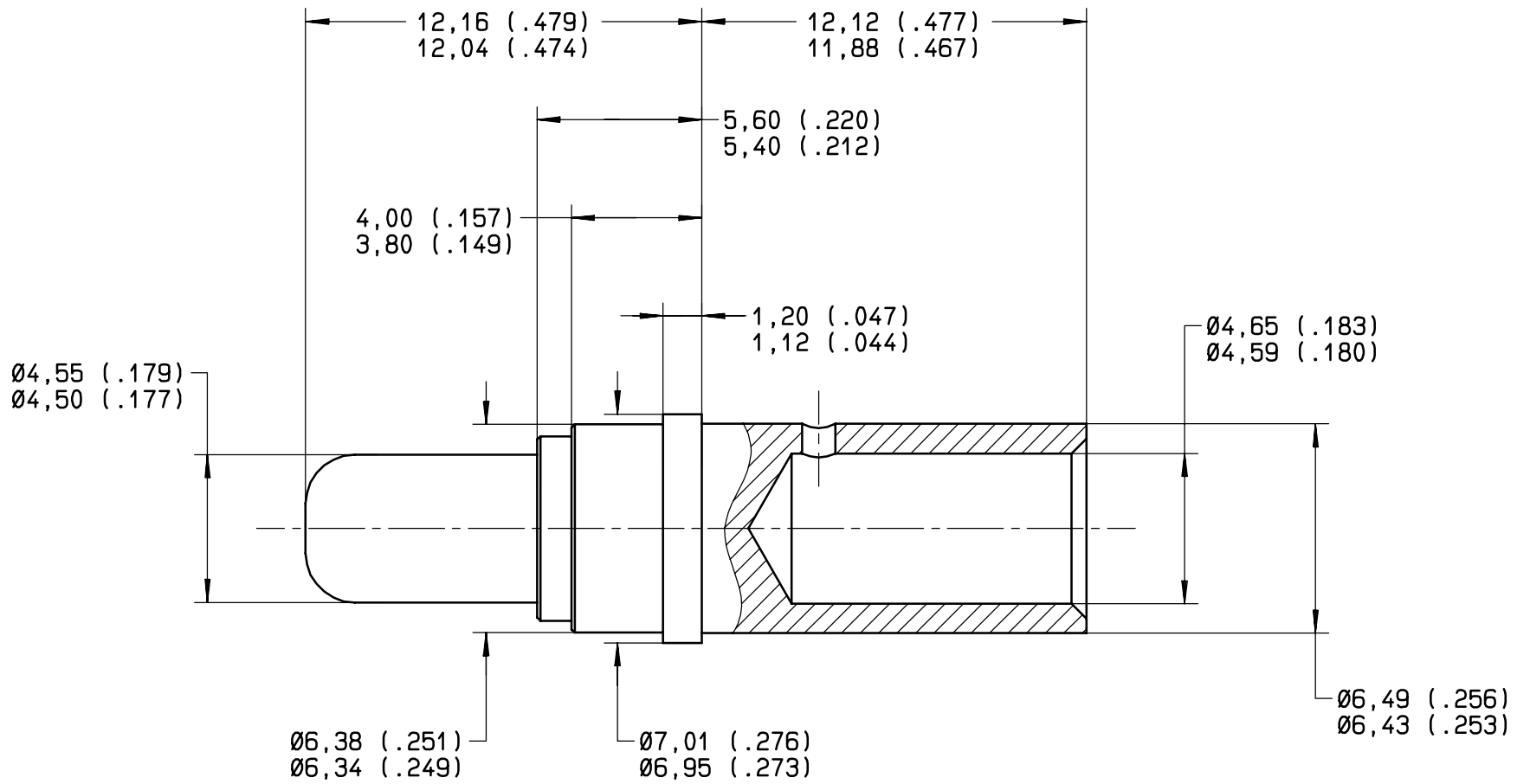

Cable stripped length:

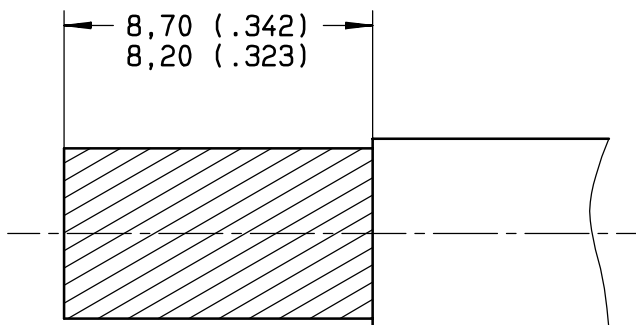

Material and finish: copper alloy, gold over nickel.

Crimping tool: M22520/23-01.

Die set: M22520/23-2.

Locator, RADIALL P/N: 282 557 020.

Extraction tool: M81969/28-01, RADIALL P/N: 282946.

This information is given as an indication. In the continual goal to improve our products, we reserve the right to make any modifications judged necessary.

4112-9610

CREATION				
PEN: 92041				
NOM: JP. Macari				
DATE: June 16, 92	05.07.99	Redraw. Added cables size, die and locator. Ø6,49(.256)/6,43(.253) was 6,40(.252)/6,32(.248)	L.Garcia	
APPR.:	Issue	Revisions	Name	Approved